

TS 600

.A5

Copy 1

TINSMITHING



AMERICAN SCHOOL OF CORRESPONDENCE

AT

ARMOUR INSTITUTE OF TECHNOLOGY

CHICAGO

U. S. A.

ILLINOIS

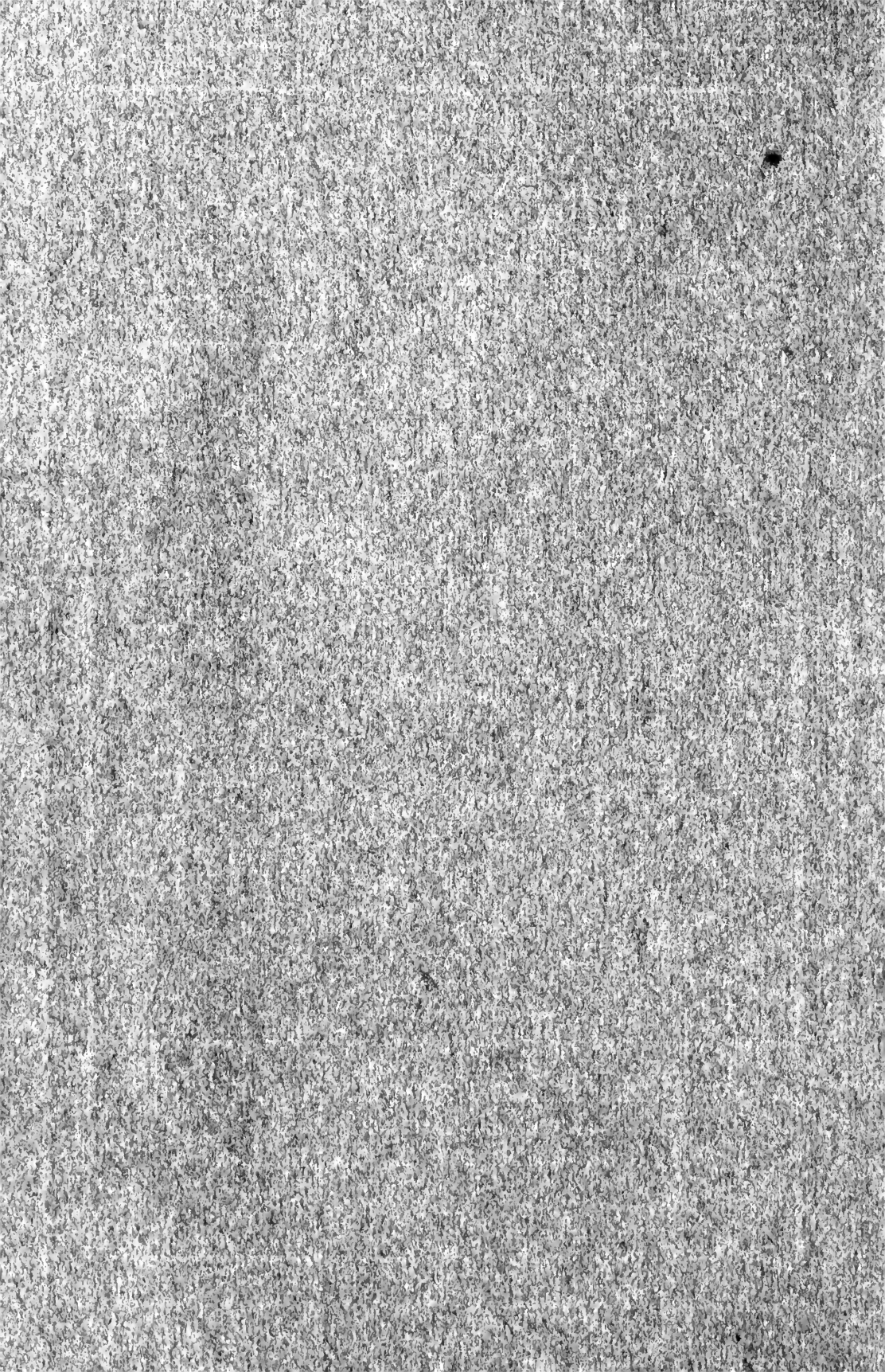

TINSMITHING

INSTRUCTION PAPER

PREPARED BY

WILLIAM NEUBECKER

INSTRUCTOR SHEET METAL DEPARTMENT OF NEW YORK TRADE SCHOOL

FORMERLY SUPERINTENDENT FORESTER CO.

1903

AMERICAN SCHOOL OF CORRESPONDENCE

AT

ARMOUR INSTITUTE OF TECHNOLOGY

CHICAGO

U. S. A.

ILLINOIS

7045

THE LIBRARY OF
CONGRESS,
Two Copies Received:
JUL 16 1903
Copyright Entry
July 11-1903
CLASS. a REG. No.
62805
COPY B.

COPYRIGHT 1903 BY
AMERICAN SCHOOL OF CORRESPONDENCE

YRARDU ENT
2290000 70

TINSMITHING.

An important part of the technical education of those connected with tinsmiths' work is a knowledge of laying out patterns. When making the various forms of tinware, or, as they are commonly called, housefurnishing goods, the greatest care must be taken in developing the patterns, for if a mistake of but one point is made, the pattern will be useless. There are general geometrical principles which are applied to this work which, when thoroughly understood, make that part plain and simple, which would otherwise appear intricate. These principles enable the student to lay out different patterns for various pieces of tinware where the methods of construction are similar.

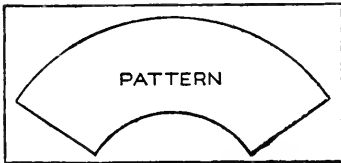

Fig. 1.

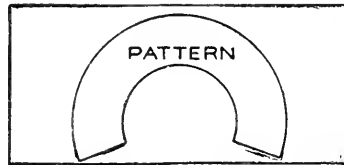

Fig. 2.

Construction. Before laying out the pattern for any piece of tinware, the method of construction should be known. Knowing this, the first thought should be: Can the pattern be developed and cut from one piece of metal to advantage, as shown in Fig. 1, or will it cut to waste, as shown in Fig. 2? Will the articles have soldered, grooved or riveted seams, as shown respectively by A, B and C, in Fig. 3? Also, will the edges be wired or have hem edges at the top, as shown respectively by A and B, in Fig. 4? Sometimes the pattern can be laid out in such a way that the article may be made up of two or more pieces, so that the patterns may be laid in one another, as shown in Fig. 5, thereby saving material. This is a plan that should always be followed if possible.

When the patterns are developed, tin plate should be obtained of such size as to have as little waste as possible.

By means of the table on pages 45-47 tin plate may be ordered

which will cut to advantage, for there is nothing worse in a tinshop than to see a lot of waste plate under the benches, whereas a little foresight in ordering stock would have saved material.

Capacity of Vessels. Sometimes the tinsmith is required to make a piece of tinware which will hold a given quantity of liquid. The methods of finding the dimensions are given in Arithmetic and Mensuration, which subjects should be reviewed before beginning this work.

Shop Tools. The most important hand tools required by the tinsmith are: hammer, shears, mallet, scratch awl, dividers and soldering coppers. The other tinsmith tools and machines will be explained as we proceed.

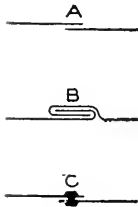

Fig. 3.

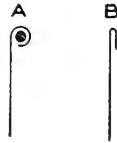

Fig. 4.

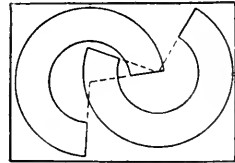

Fig. 5.

Various Methods of Obtaining Patterns. The pattern drafting for this course is divided into two classes:

1. Patterns which are developed by means of parallel lines.
2. Patterns which are developed by means of radial lines.

The principles which follow are fundamental in the art of pattern cutting and their application is universal in tinsmiths' work.

INTERSECTIONS AND DEVELOPMENTS.

The laying out of patterns in tinsmiths' work belongs to that department of descriptive geometry, known as development of surfaces, which means the laying out flat of the surfaces of the solids, the flat surfaces in this case being the tinplate. In Fig. 6 is shown one of the most simple forms to be developed by parallel lines, that of an octagonal prism. This problem explains certain fixed rules to be observed in the development of all parallel forms, which are as follows:

1. There must be a *plan*, *elevation* or other view of the article to be made, showing the line of joint or intersection, and

in line with which must be drawn a section or profile of the article. Thus, ABCD shows the view of the article, AL the line of joint or intersection, and E the profile or section of the article.

2. The *Profile* or section (if curved) must be divided into equal spaces (the more spaces employed the more accurate will be the pattern), from which lines are drawn parallel to the lines of the article intersecting the line of joint or intersection. Thus from the corners numbered 1 to 8 in the profile E, lines are drawn

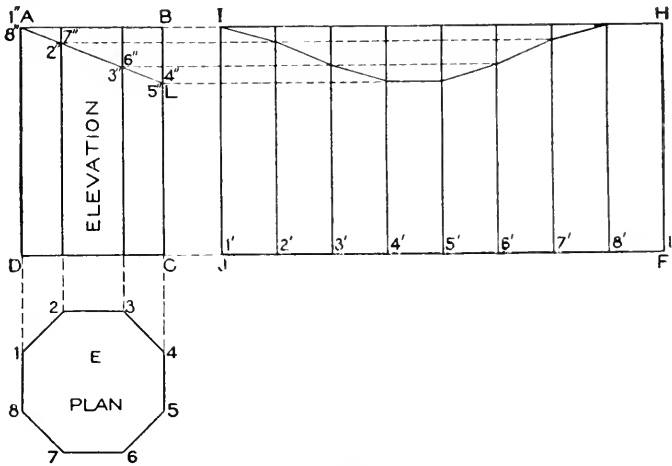

Fig. 6.

parallel to the line of the article, intersecting the line of joint AL from 1" to 8". In Fig. 7, where the section A is curved, this is divided into equal spaces.

3. A *stretchout* line (showing the amount of material the article will require) is next drawn at right angles to the line of the article, upon which is placed each space contained in the section or profile. Thus JF, in Fig. 6, is the stretchout line, which contains the true amount required to enclose the profile E.

4. At right angles to the stretchout line, and from the intersections thereon, draw lines called the *measuring lines*. Thus, from the intersections 1' to 8' on JF lines are drawn at right angles to the stretchout line JF, which are called measuring lines.

5. From the intersections on the line of joint draw lines intersecting similarly numbered measuring lines, which will result in the pattern shape. Thus lines drawn from the intersections on

the line AL at right angles to BC intersect similarly numbered measuring lines as shown. Then $JHIF$ will be the development for an octagonal prism intersected by the line AL in elevation.

This simple problem shows the fundamental principles in all parallel-line developments. What we have just done is similar to taking the prism and rolling it out on a flat surface. Let the student imagine the prism before him with the corners blackened

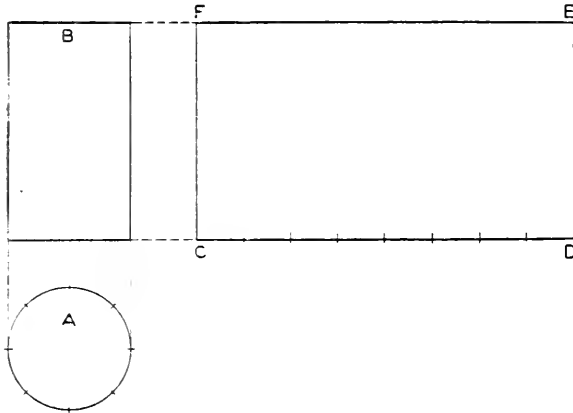

Fig. 7.

and starting with corner 1 turn the prism on a sheet of white paper until the point 1 is again reached, when the result will correspond to the development shown. Bearing these simple rules in mind, the student should have no difficulty in laying out or developing the forms which will follow.

Fig. 7 shows the development of a cylinder, and also shows the principles which are applied in spacing circular sections or profiles, as explained for parallel developments. A shows the profile or section, B the elevation, and CD the stretchout line or the amount of material required to go around the circle. By drawing the measuring lines CF and DE and connecting them by the line FE , we obtain $CDEF$, which is the development of the cylinder.

Fig. 8 shows how to obtain the development of the surfaces of an intersected hexagonal prism, the angle of intersection being 45° . First draw the elevation $ABCD$ and the section E in its proper position below. Number the corners in the section 1, 2 and 3, as shown, from which erect perpendicular lines intersecting the

plane AB, as shown by 1, 2 and 3. Bisect the lines 1—1 and 3—3 in plan obtaining the points F and H respectively, and draw the line FH. This line will be used to obtain dimensions with which to construct the developed surface on the plane AB. At right angles to AB and from the intersections 1, 2 and 3 draw lines as shown. Parallel to AB draw the line F^v H^v. Now, measuring in each instance from the line FH in E, take the distances to 1, 2 and 3, and place them on similarly numbered lines drawn from the plane AB, measuring in each instance from the

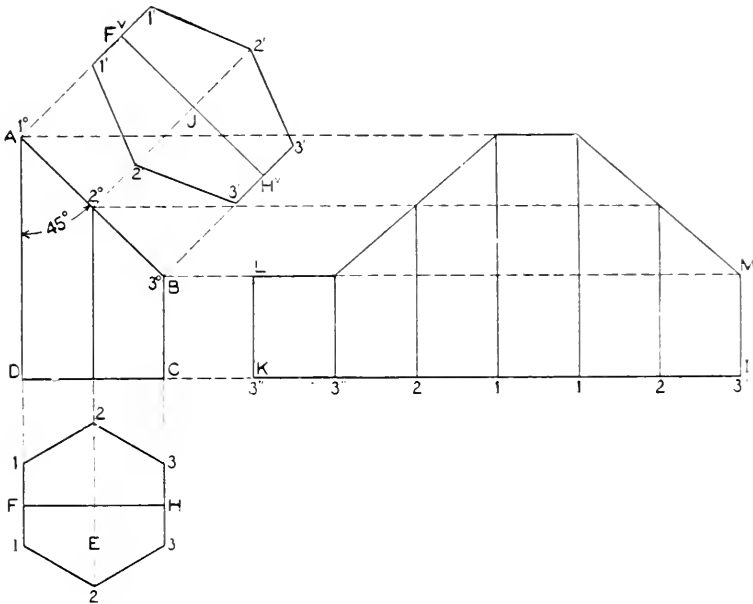

Fig. 8.

line F^vH^v on either side, thus obtaining the points 1', 2' and 3'. Connect these points by lines as shown; then J will be the true development or section on AB.

For the development of the prism, draw the stretchout line KI at right angles to AD, upon which place the stretchout of the section E, as shown by similar numbered intersections on KI. From these intersections, at right angles to KI, draw the measuring lines shown, which intersect with lines drawn from similar numbered intersections on the plan AB, at right angles to BC. Through the intersections thus obtained, draw the lines from L to

M. Then KLMI will be the pattern or development of the intersected prism.

Fig. 9 shows the development of an intersected cylinder. A is the elevation and B the profile or plan. As each half of the development will be symmetrical, divide the profile B into a number of equal parts, numbering each half from 1 to 5, as shown. From these points perpendicular lines are erected, intersecting the plane $1^v - 5^v$ at $1^v, 2^v, 3^v, 4^v$ and 5^v . A stretchout is now made of the profile B and placed on the horizontal stretchout line CD, the points being shown by $5', 4', 3', 2', 1', 2'', 3'', 4''$ and $5''$. From

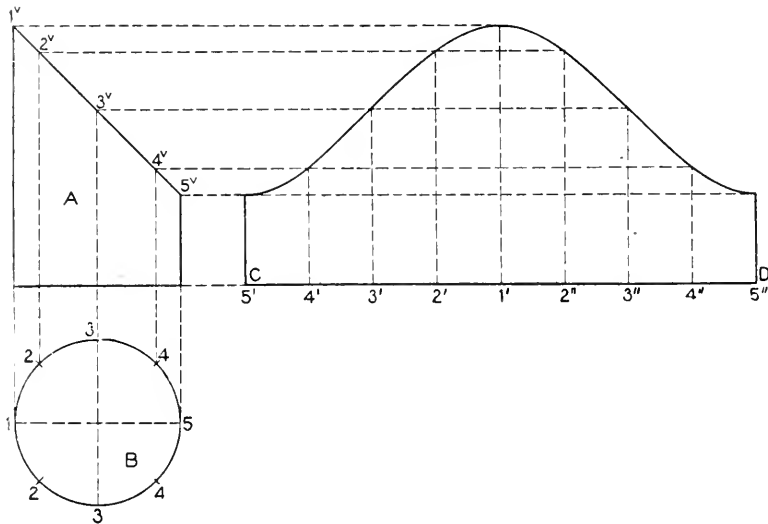

Fig. 9.

these points measuring lines are erected and intersected by similar numbered lines drawn from the plane $1^v - 5^v$ at right angles to the line of the cylinder. A line traced through points thus obtained will be the development of the intersected cylinder. In this case the butting edge or joint line of the cylinder is on its shortest side. If the butting edge were desired on its longest side, it would be necessary to change only the figures on the stretchout line CD, making $1'$ start at $5'$ and end at $5''$.

Where two prisms intersect each other, as shown in Fig. 10, it is necessary to find the points of intersection before the surfaces can be developed. Thus we have two unequal quadrangular

prisms intersecting diagonally at right angles to each other. We first draw the section of the horizontal prisms as shown by B in the end view, from which the side view A is projected as shown. From the corner T in the section B erect the perpendicular line TC, and above in its proper position draw the section D of the vertical prism, and number the corners 1, 2, 3 and 4. From the corners 1 and 3 drop vertical lines intersecting the profile B at 1' and 3', T representing the points 2' and 4' obtained from 2 and 4 in D. From the points 1' and 3' in B, draw a horizontal line through the side view, and locate the center of the vertical prism as 3'', from which erect the perpendicular line 3'' — 1. Now take a duplicate of the section D and place it as shown by F, allowing it to make a quarter turn (90°); in other words, if we view the vertical prism from the end view, the point 1 in section D faces the left, while if we stood on the right side of the end view the point 1 would point ahead in the direction of the arrow. The side view therefore represents a view standing to the right of the end view, and therefore the section F makes a quarter turn, bringing the corner 1 toward the top. From points 2 and 4 in section F drop vertical lines intersecting the line drawn from the corner 2' — 4' in B, thus obtaining the intersections 2'' — 4'' in the side view. Draw a line from 4'' to 3'' to 2'', which represents the intersection between the two prisms.

To develop the vertical prism, draw the horizontal stretchout line III, and upon it place the stretchout of the profile D as shown by similar figures on III. Draw the measuring lines from the points 1, 2, 3, 4, 1, at right angles to III, which intersects with lines drawn at right angles to the line of the vertical prism from intersections having similar numbers on B. A line traced through the points thus obtained, as shown by IIIJ will be the development of the vertical prism. The development of the horizontal prism with the opening cut into it to admit the joining of the vertical prism is shown in Fig. 11, and is drawn as follows: Draw any vertical line O^v P^v, and on this line place the stretchout of the upper half of section B in Fig. 10, as shown by similar letters and figures in Fig. 11. From these points at right angles to O^v P^v draw lines equal in length to the side view in Fig. 10. Draw a line from U to T in Fig. 11. Now, measuring from the line RS in side view in Fig. 10, take the various distances to points of in-

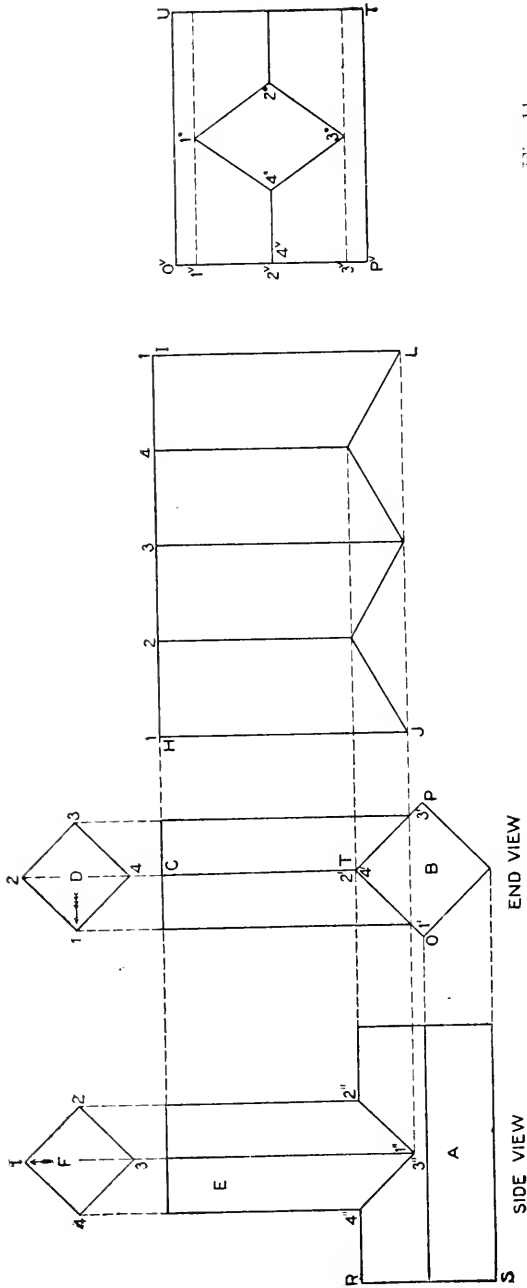

END VIEW
Fig. 10.

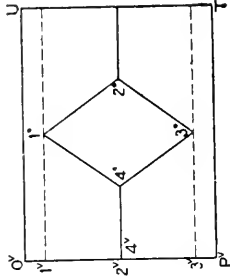

Fig. 11.

intersections 4", 3", 1" and 2", and place them in Fig. 11 on lines having similar numbers, measuring from the line $O'v'P'$, thus resulting in the intersections 1, 2, 3 and 4. Connecting these points by lines as shown, then $O'v'UT'P'$ will be the half development of the top of the horizontal prism. The bottom half will be similar without the opening.

Having described the principles relating to parallel forms, the next subject will be the principles relating to tapering forms. These forms include only the solid figures that have for a base the circle, or any of the regular polygons, also figures of unequal sides which can be inscribed in a circle, the lines drawn from the corners of which terminate in an apex, directly over the center of the base. The forms with which the tinsmith has to deal are more frequently frustums of these figures, and the method used in developing these surfaces is simply to develop the surface of the entire cone or pyramid, and then by simple measurements cut off part of the figure, leaving the desired frustum. Thus in the well-known forms of the dipper, coffee pot, colander, strainer, wash bowl, bucket, funnel, measure, pan, etc., we have the frustums of cones above referred to. In speaking here of metal plate articles as portions of cones, it must be remembered that all patterns are of surfaces, and as we are dealing with tinplate, these patterns when formed are not solids, but merely shells. In works upon Solid Geometry the right cone is defined as a solid with a circular base, generated by the revolution of a right-angle triangle about its vertical side called the axis.

This is more clearly shown in Fig. 12, in which is shown a right cone, which contains the principles applicable to all frustums of pyramids and cones. ABC represents the elevation of the cone; the horizontal section on the line BC being shown by $GDEF$, which is spaced into a number of equal parts, as shown by the small figures 1 to 10. As the center or apex of the cone is directly over the center a of the circle, then the length of each of the lines drawn from the small figures 1 to 10 to the center a will be equal both in plan and elevation. Therefore to obtain the envelope or development, use AB or AC as radius, and with A in Fig. 13 as center, describe the arc $1-1'$. From 1 draw a line to A and starting from the point 1, set off on the arc $1-1'$ the stretchout or num-

ber of spaces contained in the circle DEFG in Fig. 12, as shown by similar figures in Fig. 13. From V draw a line to A . Then $A-1-7-V$ will be the development of the right cone of Fig. 12.

Suppose that a frustum of the cone is desired as shown by HICB, Fig. 12; then the opening at the top will be equal to the small circle in plan, and the radius for the pattern will be equal to AI . Now using A in Fig. 13 as a center with AI as radius, describe the arc HI , intersecting the lines IA and AI' at H and I respectively. Then $H-I-I'-7-1$ will be the development for the frustum of the cone.

When a right cone is cut by a plane passed other than parallel to its base, the method of development is somewhat different. This

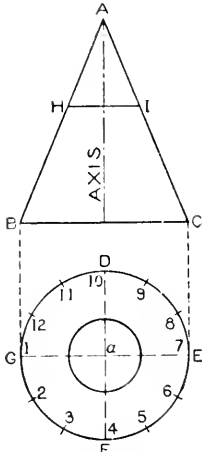

Fig. 12.

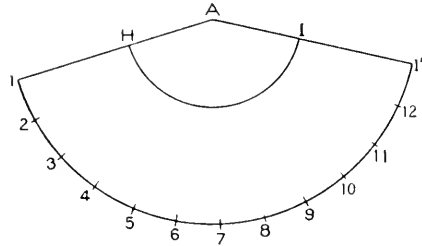

Fig. 13.

is explained in connection with Fig. 14, in which A is the right cone, intersected by the plane represented by the line DE . B represents the plan of the base of the cone, whose circumference is divided into equal spaces. As the intersection of both halves of the cone are symmetrical, it will be necessary to divide only half of plan B as shown by the small figures 1 to 7. From these points, erect lines parallel to the axis of the cone, intersecting the base line of the cone. From these points draw lines to apex F , intersecting the line DE as shown. From the intersections thus obtained on the line DE and at right angles to the axis, draw lines as shown, intersecting the side of the cone FE . Now using F as center and FI as a radius, describe the arc $7-7'$. From 7 draw a line to F , and

starting from the point 7 set off on the arc $7-7'$, the stretchout of the circle B as shown by the small figures $7-1-7'$. From these points draw radial lines to the center point F, and intersect them by arcs struck from the center F, with radii equal to similarly numbered intersections on the side FH, and partly shown by points $7^v-1^v-7'$. Trace a line through the points of intersections thus obtained; then $7-7^v-7'-7'$ will be the desired development.

These same principles are applicable no matter at what angle the cone is intersected. For the section on the line DE, see the explanation in Mechanical Drawing Part III.

Fig. 15 shows the principles applicable to the developments of pyramids having a base of any shape. In this case, we have a square pyramid, intersected by the line DE. First draw the elevation of the pyramid as shown by ABC and in its proper position the plan view as shown by 1, 2, 3, 4. Draw the two diagonal lines 1-3 and 2-4 intersecting each other at A'. The length of the line AC represents the true length on A'4, but is not the correct radius with which to strike the development.

A true length must be obtained on the line A'4 as follows: At right angles to 3-4 from the center A' draw the line A'E' and using A' as center and A'4 as radius, describe the arc 4E' intersecting A'E' at E'. From E' erect the perpendicular line E'1^v intersecting the base line BC extended at 1^v. From 1^v draw a straight line to A, which will be the true length on A'4 and the radius with which to strike the development. (See also Part III, Mechanical Drawing) Now with A as center and A-1^v as radius, describe the arc 1^v-3^v-1^v. Starting

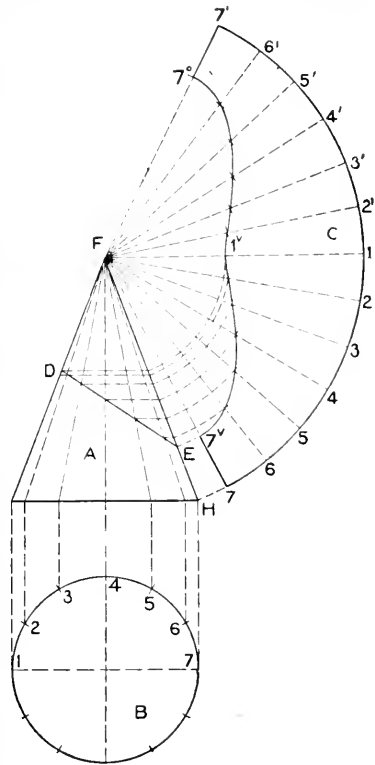

Fig. 14.

from 1^v set off the stretchout of $1-2-3-4-1$ in plan, as shown by $1^v-2^v-3^v-4^v-1^v$ on the arc 1^v-1^v (1^v-2^v being equal to $1-2$, etc.), and from these points draw lines to the apex A and connect points by straight lines as shown from 1^v to 2^v , 2^v to 3^v , 3^v to 4^v and 4^v to 1^v . Then $A1^v3^v1^v$ will be the development of the square pyramid.

To obtain the cut, in the development of the intersected plane

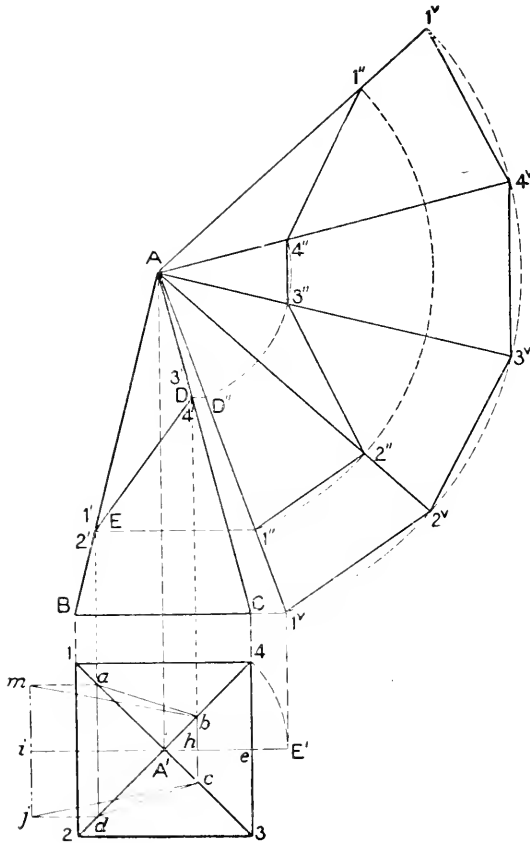

Fig. 15.

DE, which represents respectively the points 3^1-4^1 and 1^1-2^1 , draw at right angles to the center line, the lines $D-D''$ and $E-E''$, intersecting the true length $A1^v$ at D'' and E'' . Using A as center and radii equal to $A-D''$ and $A-E''$ intersect similarly numbered radial lines in the development. Connect these points as shown

from 1" to 2", 2' to 3", 3" to 4" and 4" to 1". Then 1" - 1v - 3v - 1v - 1" - 3" will be the development of the intersected square pyramid.

To draw DE in plan drop perpendiculars from D and E intersecting the diagonal lines in plan at *b c* and *d a*. Connect lines as shown at *a, b, c* and *d*. To obtain the true section of the plane DE, take the length of DE and place it, as shown in plan from *h* to *i*; through *i* draw the vertical line *j m* which is intersected by horizontal lines drawn from points *a* and *d*. Draw a line from *b* to *m* and *c* to *j* which will be the desired section.

These problems just described should be thoroughly studied and practiced on paper, until every step is well understood.

Practical Workshop Problems will now be considered, and the student who thoroughly understands the principles explained in the foregoing problems, will be able to develop the patterns with greater ease and in less time than is required by the student, who pays little attention to the principles, but simply proceeds to develop the patterns by blindly following directions. A thorough knowledge of the principles renders the student independent as far as pattern problems are concerned, as he can apply them to new work.

Short Rules. There are various short rules, which, while not geometrically accurate, are sufficiently so for all practical purposes and will be introduced as we proceed. In developing patterns for any given article, the problem should be gone over carefully, locating the joints or seams, so that it can be seen, we might say in our minds' eye; by doing this a shorter rule may be employed, thus saving time and expense. The student who pays attention to these smaller details will succeed as a pattern draftsman.

Allowance for Seaming and Wiring. As we are dealing with tin plate only, we assume this to have no thickness, and therefore make no allowance for the shrinkage of the metal, when bending in the machine folder or brake.

The amount of the material to be added to the pattern for wiring will vary according to the thickness of the metal. A safe and practical plan is to use a small strip of thin metal about $\frac{1}{4}$ inch wide and curl this around the wire which is to be used as shown in Fig. 16. This will give the true amount of material required, whether the wire is to be laid in by hand or by means of the wiring machine. First bend off with plyers a sharp corner as shown at *a*,

place the wire in the corner and turn A snugly around the wire as shown at B. The amount of A, or the allowance to be added to the height of the pattern is thus obtained. The vertical joint in tinware is usually a lock seam as shown in Fig. 17. Three times the width of the lock a must be added to the pattern. In other words, the end b has a single edge as d , while the other end c has a double edge as shown at e and f ; the two ends of the body joining at f .

In allowing these edges for the pattern, some workmen prefer to add a single edge on one side of the pattern, and a double edge on the other, while others prefer to allow one-half of the amount required on either side of the pattern. Where the bottom of any piece of tinware is to be joined to the body, it is generally double

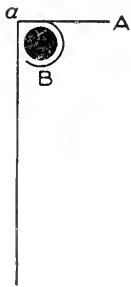

Fig. 16.

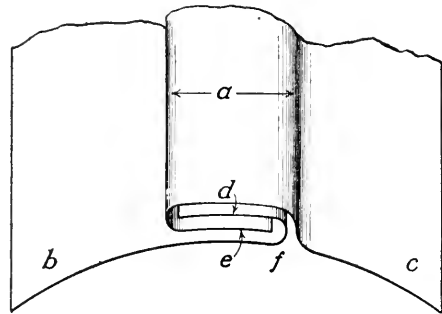

Fig. 17.

seamed as is shown in Fig. 18, where the two operations are clearly shown by A and B whether the seaming is done by hand or machine, while the lock seam in Fig. 17, is done on the groover.

Notching the Patterns. Another important point is the notching of the edges of the patterns for seaming and wiring; special attention should be given to this. The notches should be made in such a manner that when the article is rolled up and the wire encased or the seams grooved, the ends of the wire or seam allowance will fit snugly together and make a neat appearance. When an article is made and the notches have not been cut properly, the wire, or uneven lines, will show at the ends of the seam. Fig. 19 shows how the allowance for wire or locks should be cut. A shows the pattern to which an allowance has been made for wire at B and for seaming to the bottom at C. In this case a single edge D has been allowed at one end of the pattern

and a double edge of the other as shown at E. Then, using this method of allowance for seaming, notch the allowance for wire B and seam C on a line drawn through the solid lines in the pattern as shown by *aa* and *bb*. The notches of the allowance D and E should be cut at a small angle, as shown.

Transferring Patterns. After the pattern has been developed on manilla paper, which is generally used in the shop, it is placed on the tin plate and a few weights laid on top of the paper; then with a sharp scratch awl or prick punch and hammer, slight prick-punch marks are made, larger dots indicating a bend. The paper is then removed and lines scribed on the plate, using the scratch awl for marking the straight lines, and a lead pencil for the curved lines. After laps are added as required, it is ready to be cut out with the shears.

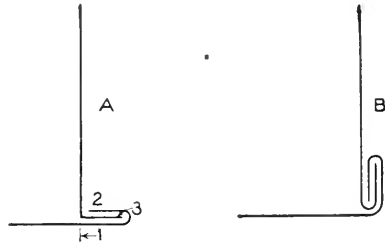

Fig. 18.

PRACTICAL PROBLEMS.

In presenting the twelve problems which follow, particular attention has been given to those problems which arise in shop practice. These problems should be practiced on cheap manilla paper, sealing them to the most convenient size, and then proving them by cutting the patterns from thin card board, and bending or forming up the models. This will prove both instructive and interesting.

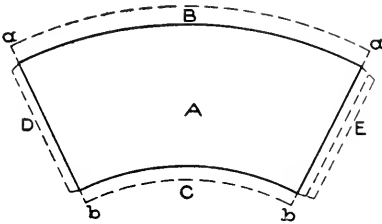

Fig. 19.

Pail. The first piece of tinware for which the pattern will be developed is that known as the flaring bucket, or pail, shown in Fig. 20. First draw the center line AB, Fig. 21, upon which place the height of the pail, as shown by CD. On either side of the center line place the half diameters CE of the top and DF of the bottom. Then EFFE will be the elevation of the pail. Extend the lines EF until they meet the center line at B, which will

be the center point with which to describe the pattern. Now, with C as center and CE as radius, describe the semi-circle CAE, and divide it into equal spaces, as shown. This semi-circle will represent the half section of the top of the pail.

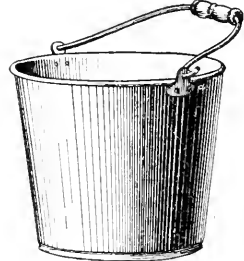

Fig. 20.

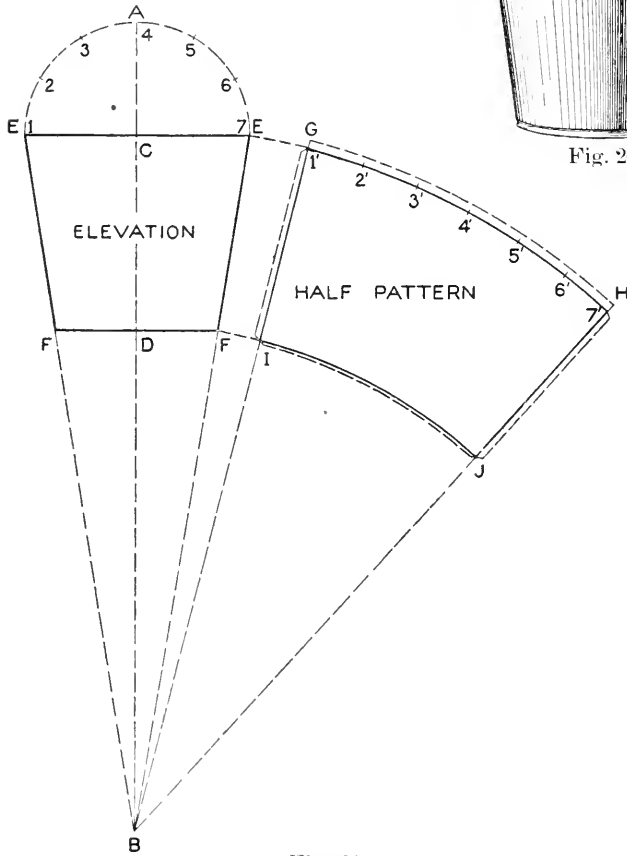

Fig. 21.

For the pattern proceed as follows: With B as center and radii equal to BF and BE, describe the arcs GH and IJ. Draw a line from G to B. Starting from the point G lay off on the arc GH, the stretchout of the semi-circle EAE, as shown by similar figures on GH. From H draw a line to B, intersecting the arc IJ at J. Then GHJI will be the half pattern for the pail, to which laps must be added for seaming and wiring as shown by the dotted lines.

Funnel and Spout. In Fig. 22 is shown a funnel and spout, which is nothing more than two frustums of cones joined together.

Fig. 23 shows how the patterns are developed. In this figure the full elevation is drawn, but in practice it is necessary to draw only one-half of the elevation, as shown on either side of the center

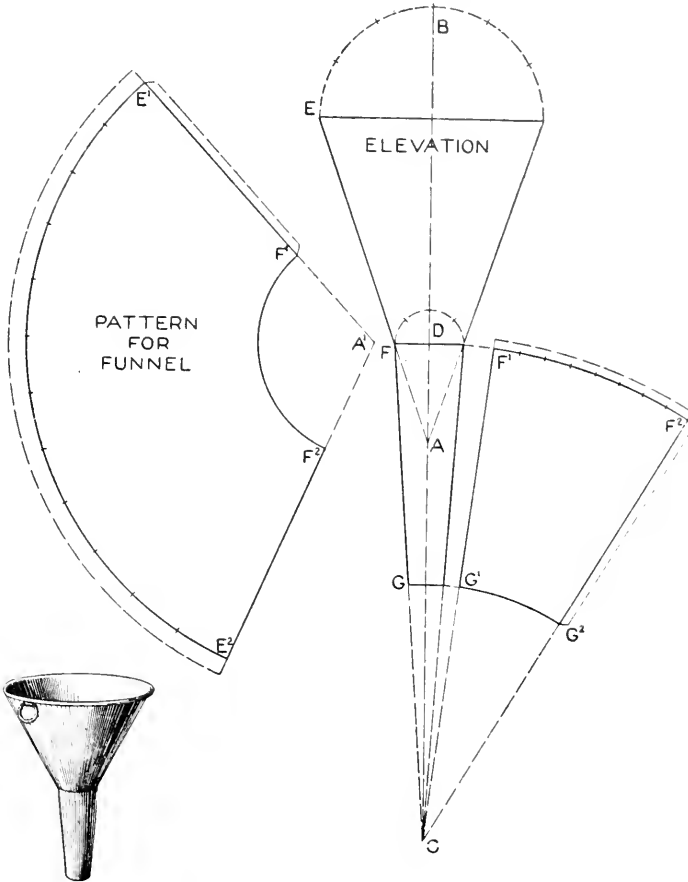

Fig. 22.

Fig. 23.

line BC. Extend the contour lines until they intersect the center line at C and A. Now, using A' as a center, with radii equal to AF and AE, describe the arcs F'F² and E'E² respectively. On the arc E'E² lay off twice the number of spaces contained in the semi-circle B, then draw radial lines from E¹ and E² to A', intersecting the inner arc at F¹F², which completes the outline for the

pattern. Laps must be allowed for wiring and seaming. For the pattern for the spout use C as a center, and with radii equal to CG and CF describe the arcs F^1F^2 and G^1G^2 . On F^1F^2 lay off twice the amount of spaces contained in the semi-circle D , and draw radial lines from F^1 and F^2 to C . Then $F^1F^2G^1G^2$ will be the pattern for the spout. The dotted lines show the edges allowed.

Hand Scoop. In Fig. 24 is shown a perspective view of a hand scoop, in the development of which the parallel and radial line developments are employed. Thus A and B represent intersected cylinders, while C represents an intersected right cone. The method of obtaining the patterns for the hand scoop is clearly shown in Fig. 25; these principles are applicable to any form of hand scoop.

First draw the side view of the scoop as shown, in line with which place the half section; divide this into a number of equal spaces as shown by the figures 1 to 7.

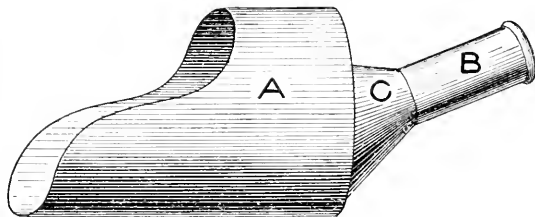

Fig. 24.

From these points draw horizontal lines intersecting the curve of the scoop. In line with the back of the scoop draw the vertical line $V-V'$, upon which place the stretchout of twice the number of spaces contained in the half section, as shown by similar numbers on the stretchout line. From these points on the stretchout line draw horizontal lines, which intersect lines drawn from similarly numbered points on the curve of the scoop parallel to the stretchout line. Trace a line through points thus obtained, which will give the outline for the pattern for the scoop, to which edges must be allowed as shown by the dotted line. The pattern for the back of the scoop is simply a flat disc of the required diameter, to which edges for seaming are allowed.

When drawing the handle, first locate the point at which the center line of the handle is to intersect the back of the scoop, as at 2. Through this point, at its proper or required angle, draw the center line 2-2'. Establish the length of the handle, and with any point on the center line as center, draw the section

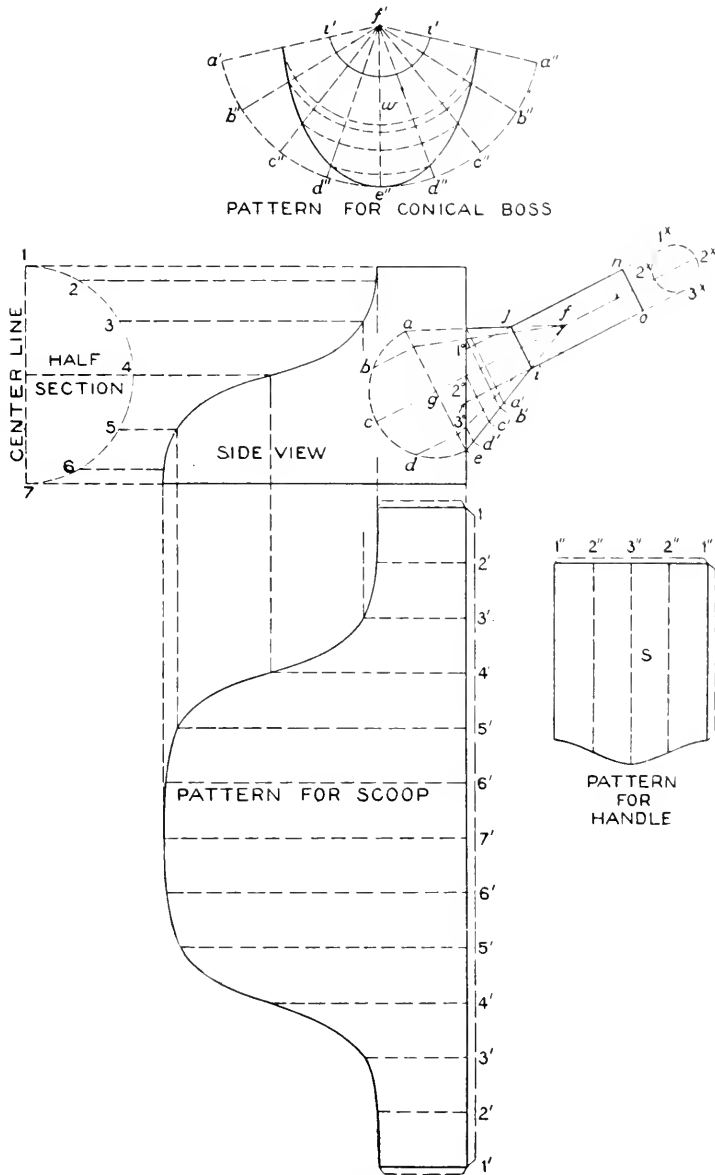

Fig. 25.

as shown by 1^x, 2^x 3^x, and 2^x, and divide the circumference into equal spaces, in this case four. (In practical work it would be better to use more than four). Parallel to the center line and from these four divisions draw lines as shown intersecting the back of the scoop at 1, 2 and 3. For the pattern draw any horizontal line in S, as 1''3''1'', upon which place the stretchout of the section of the handle as shown by 1'' 2'' 3'' 2'' 1'' on the stretchout line. From these points at right angles to the line of the stretchout, draw lines as shown. Take the various distances measuring from the line *oo* in side view to points 1, 2 and 3, and place them on lines drawn from similar numbers in S, measuring from the line 1''3''1''. A line traced through these points of intersection will be the pattern for the handle, laps being indicated by dotted lines. To close the top of the handle *oo*, a small raised metal button is usually employed, which is double-seamed to the handle.

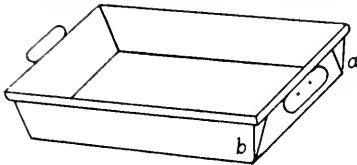

Fig. 26.

To draw the conical boss in side view, first locate the points *i* and *e*, through which draw a line intersecting the center line of the handle at *f*'. At right angles to the center line, draw the line *j*' representing the top opening of the boss. In similar manner, at right angles to the center line, draw a line from *e* as shown by *ee'*, intersecting the center line at *g*'. Now make *ga* equal to *ge* and draw a line from *a* to the center, *f*', which will intersect the back of the scoop as shown and the top of the boss at *j*'. With *g* as center and *ga* as radius describe the half section of the cone, divide this into equal spaces as shown by *abcde*, from which draw lines at right angles to and intersecting the base of the cone *ae* as shown. From the intersections on the base line draw radial lines to the apex, *f*', intersecting the back of the scoop as shown. From these intersections at right angles to the center line, draw lines intersecting the side of the boss at *a'b'c'd'*'. For the pattern proceed as shown in diagram *w*. With radius equal to *f'c'* in the side view and *f'* in *w*, as a center describe the arc *a'd''*. Draw a line from *a''* to the center, *f'*, and starting from *a''* set off on the arc *a'd''* twice the number of spaces contained in the semi circle *ace* in side view, as shown by similar letters in diagram *w*. From these points

draw radial lines to the center f' . Now using f' in w as a center describe the arc $f'z'$. In similar manner, using as radii $f'a'$, $f'b'$, $f'c'$, $f'd'$ and $f'e'$ in side view, and f' in w as center, describe arcs intersecting radial lines having similar letters as shown. A line traced through points thus obtained forms the pattern for the conical boss.

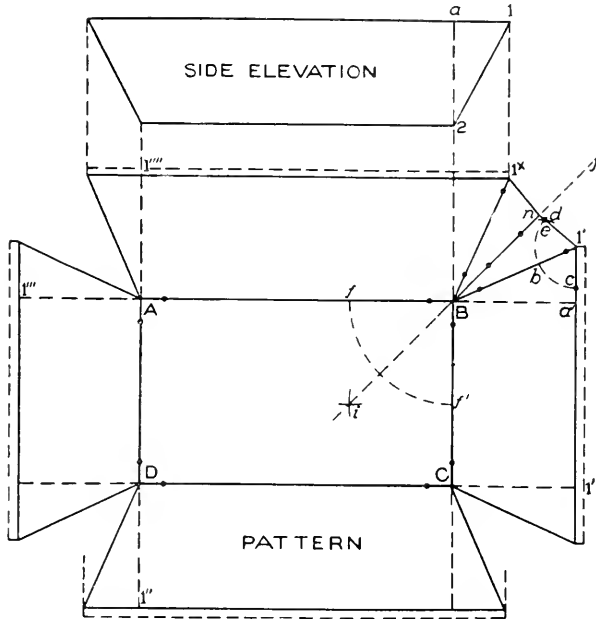

Fig. 27.

Drip Pan. Fig. 26 shows a view of a drip pan with beveled sides. The special feature of this pan is that the corners a and b are folded to give the required bevel and at the same time have the folded metal come directly under the wired edge of the pan. A pan folded in this way gives a water tight joint without any soldering. Fig. 27 shows the method of obtaining the pattern when the four sides of the pan have the same bevel. First draw the side elevation having a bevel indicated at $a21$. Now draw $ABCD$, a rectangle representing the bottom of the pan. Take the distance of the slant $1-2$ in elevation and add it to each side of the rectangular bottom as shown by $1'$, $1''$, $1'''$ and $1''''$. Through these points draw lines parallel to the sides of the bottom as shown. Now extend the lines of the bottom AB , BC , CD and DA intersecting the lines just drawn. Take the projection of the bevel

a to 1 in side elevation and place it on each corner of the pan, as, for example, from a' to 1'. Draw a line from 1' to B. By proceeding in this manner for all the corners, we will have the butt miters, if the corners were to be soldered raw edge. Where the bevels are equal on all four sides, the angle $1^xBI'$ is bisected as

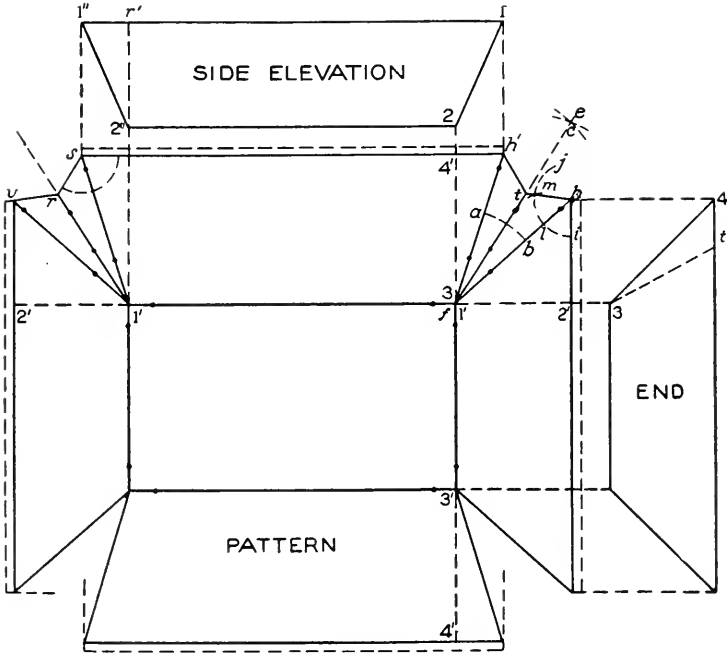

Fig. 28.

follows: With B as center and any radius draw the arc ff' intersecting the sides of the bottom as shown. Then with a radius greater than one half of ff' , with f and f' respectively as centers, draw arcs which intersect each other at i . Draw a line through the intersection i and corner B, extending it outward toward j .

Now with $1'$ as center, and radius less than one-half of $1'-1^x$, draw arc $d-c$, intersecting the line $1' B$ at b , and intersecting the line $1'a'$ at c . Then with b as center and bc as radius, intersect the arc cd at e . Draw a line from $1'$ to e , intersecting the line ij at n . From n draw a line to 1^x . Transfer this cut to each of the corners, which will complete the pattern desired. Dotted lines indicate the wire allowance.

Sometimes a drip pan is required whose ends have a different

flare from those of the sides, and in one case the folded corners are to be bent toward the end, while it may be required that the corners be folded towards the side. The principles are similar in both cases, but as the method of applying these principles may be a little difficult, Fig. 28 has been prepared, which will explain the application of these principles.

First draw the side elevation, showing the desired flare; also draw the end elevation, which shows the flare of the sides, being careful that the vertical heights in both views are the same. Now draw the bottom of the pan as follows: Take the distance 1-2 in side elevation and place it on the ends of the bottom as shown on either side by 1'-2'. Similarly take the distance 3-4 in end elevation and place it on the sides of the bottom as shown on either side by 3'-4'. Through the point 2' and 4' draw lines parallel to the ends and sides of the bottom as shown, which intersect lines dropped from the end and side views respectively. $h't'h'$ represent the butt miters which should be placed on all corners. If these miters have been correctly developed, the lengths from h to f' must be equal to $f'h'$. Bisect the angle $h't'h'$ by using f' as center and drawing the arc ab , then use a and b as centers and obtain the intersection c , through which draw the line cf' . Now assume that the folded corner is to be turned towards the end view as shown by $t'3$. Using h as a center draw the arc ij . Then with l as center and l' as radius, intersect the arc ij at m . Draw a line from h through m , meeting the line cf' at t , and draw a line from t to h' .

If the folded corner were turned towards the side as shown by $t'-2''$ in the side view, bisect the angle $t'1's$ as before, and use s as a center and proceed as already explained. Note the difference in the two corners. The only point to bear in mind is, that when the corner is to be folded towards the end, transfer the angle of the end miter; while if the corner is to be turned towards the side, transfer the angle of the side miter. If the corners were to be folded toward the ends of the pan, the cut shown in the right-hand corner would be used on all four corners, while if the corners were to be folded towards the sides, the cut shown on the left-hand corner would be used.

Tea Pot. In Fig. 29 is shown the well-known form of the tea or coffee pot, for which a short method of developing the pat-

tern is shown in Fig. 30. This is one of the many cases where a short rule can be used to advantage over the geometrical method. While it is often advisable to use the true geometrical rule, the difference between that and the method here shown is hardly noticeable in practice. Of course, if the body A and spout B were larger than the ordinary tea pots in use, it would be necessary to use the true geometrical rule, which is thoroughly explained for Plates I, II and III.



Fig. 29.

The pattern for the body of the tea pot will not be shown, only the short rule for obtaining the opening in the body to admit the joining of the spout. The method of obtaining the pattern for the body is similar to the flaring vessels shown in previous problems.

First draw the elevation of the body of the tea pot as shown at A. Assume the point a on the body and draw the center line of the spout at its proper angle as shown by $2b$. Establish the point 3 of the bottom of the spout against the body, also the point 3^x at the top and draw a line from 3 through 3^x intersecting the center line at b . At right angles to the center line and from 3 draw the line $3-1$ and make $c1$ equal to $c3$. From 1 draw a line to the center point and from 3^x draw a horizontal line until it intersects the opposite side of the spout at $1''$. Then $1'-1''-3^x-3$ will be the side view of the spout. Now with c as a center draw the half section $1-2-3$ and divide it into equal spaces; in this case but two (in practical work more spaces should be employed). From these points and at right angles to $1-3$ draw lines intersecting the base of the spout as shown, and draw lines from these points to the center b . Thus line $1b$ intersects the body at $1'$ and the top of the spout at $1''$; line $2b$ intersects the body at a and the top of the spout as shown, while line $3b$ cuts at 3 and the top of spout at 3^x . From these intersections at right angles to the center line ab , draw lines intersecting the side of the spout at $3, 2, 1$ at the bottom and $1^x, 2^x, 3^x$ at the top. Now with b as center and $b3$ as radius, describe the arc $3''-3''$ upon which place the stretchout of twice

the number of spaces contained in the half section 1-2-3, as shown by similar figures on 3''-3''; from these points draw radial lines to the center *b*, and intersect them by arcs drawn with *b* as a center and radii equal to the intersections contained on the side of

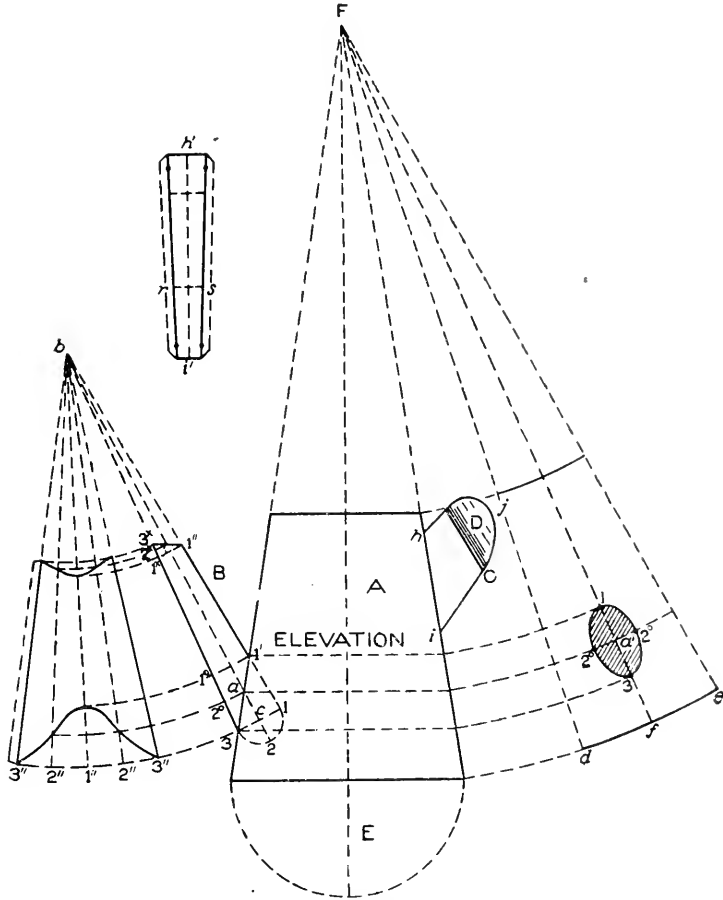

Fig. 30.

the spout 3-3^x. To form the pattern, trace a line through points thus obtained and make the necessary allowance for edges.

It should be understood that in thus developing the spout, the fact that the spout intersects a round surface has not been considered; it was assumed to intersect a plane surface. As already stated the difference in the pattern is so slight that it will not be noticeable

in practice. Had we developed the pattern according to the true geometrical rule, it would present a problem of two cones of unequal diameter intersecting each other, at other than at right angles to the axes.

For the pattern for the opening in the body, draw lines at right angles to the center line of the body from intersections 1', *a* and 3 intersecting the opposite side of the body as shown. With F as a center draw a partial pattern of the body as shown by *dc*. From any point *f'* draw a line to the center F. Now with F as center draw the arcs 1, 2 and 3. The distance 1 to 3 on the line F*f'* represents the length of the opening, while a line drawn through

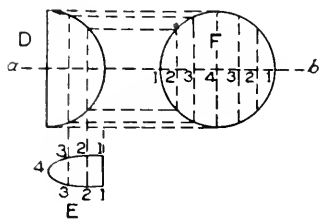

Fig. 31.

a at right angles to the center line *bc* of the spout represents the width of the opening. Therefore take the distance from *a* to 2' and place it as shown from *a'* on the line *f'F* to 2 - 2' on either side on the arc. Trace an ellipse through 1 - 2 - 3 - 2 for the shape of the opening.

The pattern for the handle is obtained by taking the stretchout of *h'j'* and placing it as shown on the vertical line *h''j''*. At right angles to *h''j''* on either side, at top and bottom add the desired width of the handle and draw the lines shown; add edges for wiring or hem edge.

For the pattern for the grasp *D* which is placed inside on the handle proceed as is shown in Fig. 31. Let *D* represent an enlarged view of part of the handle in which the grasp is to be soldered. Directly in line with it draw the section *E* taking care that the width from 1 to 1 will not be wider than that portion of the handle from *r* to *s* in Fig. 30, being the width at *C* in the elevation. Divide the section *E* in Fig. 31 into a number of equal spaces, from which draw vertical lines intersecting the curve *D* as shown. Draw the center line *ab* upon which lay off the stretchout of *E* as shown by similar figures. Through these points draw lines which intersect with lines drawn from similar intersections in the curve *D* parallel to *ab*. Trace a line through the points thus obtained as shown at *F*.

Foot Bath. In Fig. 32 is shown an oval foot bath; the principles used in obtaining the pattern of which are applicable to any

form of flaring vessels of which the section is elliptical or struck from more than two centers. In this connection it may be well to explain how to construct an ellipse, so that a set of centers can be obtained with which to strike the arcs desired. Fig. 33 shows the method of drawing an approximate ellipse, if the dimensions are given. Let AB represent the length of the foot bath and CD its width. On BA measure BE equal to CD. Now divide the distance EA into three equal parts as shown by 1 and 2. Take two of these parts as a radius, or E2, and with O as center, describe arcs intersecting the line BA at X and X'. Then with XX' as a radius and using X and X' as centers describe arcs intersecting each other at C and D. Draw lines from C to X and X' and extend them toward F and G respectively. Similarly from D draw lines through X and X', extending them towards I and H respectively. Now with X and X' as centers, and XA and X'B as radii describe arcs intersecting the lines ID, FC, GC and HD at J, K, L and M, respectively. In similar manner

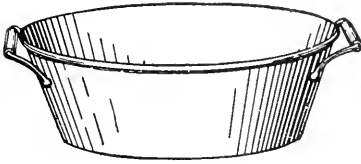

Fig. 32.

describe arcs intersecting each other at C and D. Draw lines from C to X and X' and extend them toward F and G respectively. Similarly from D draw lines through X and X', extending them towards I and H respectively. Now with X and X' as centers, and XA and X'B as radii describe arcs intersecting the lines ID, FC, GC and HD at J, K, L and M, respectively. In similar manner

with D and C as centers and DC and CD as radii describe arcs which must meet the arcs already drawn at J, M, L and K, respectively, forming an approximate ellipse. In Fig. 34 let ABCD represent the side elevation of the pan, whose vertical height is equal to RC.

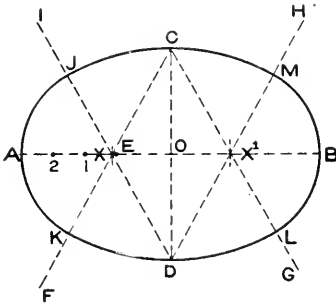

Fig. 33.

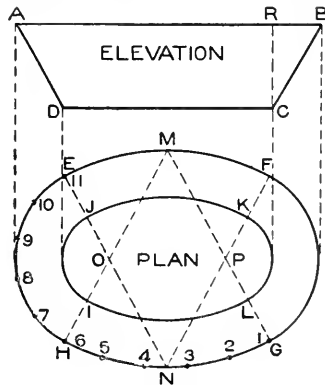

Fig. 34.

with D and C as centers and DC and CD as radii describe arcs which must meet the arcs already drawn at J, M, L and K, respectively, forming an approximate ellipse. In Fig. 34 let ABCD represent the side elevation of the pan, whose vertical height is equal to RC.

In precisely the same manner as described in Fig. 33 draw

the plan as shown, in correct relation to the elevation, letting EFGH be the plan of the top of the pan, and JKLI the plan of the bottom, struck from the centers, O, M, P and N. The next step is to obtain the radii with which to strike the pattern. Draw a horizontal line RE in Fig. 35 equal in length to NE in plan in Fig. 34. Take the vertical height RC in elevation, and place it as shown by RC in Fig. 35 on a line drawn at right angles to RE. Parallel to RE and from the point C, draw the line CJ equal to NJ in Fig. 34.

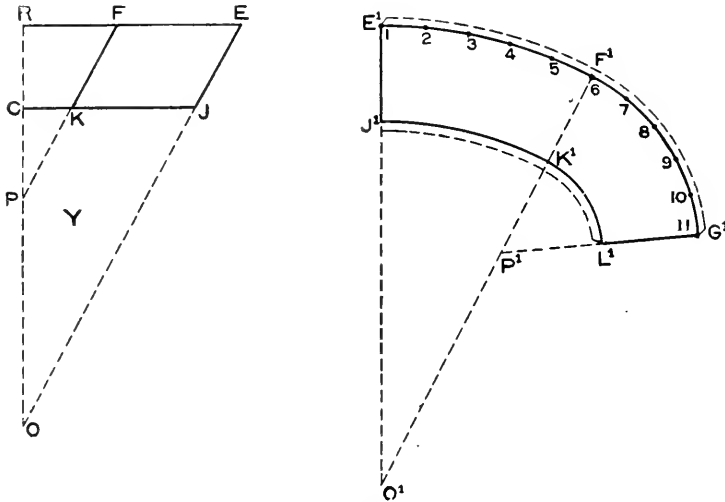

Fig. 35.

Now draw a line from E to J in Fig. 35, extending it until it meets the line RC produced. Then OJ and OE will be the radii with which to make the pattern for that part of the pan or foot bath shown in plan in Fig. 34 by EFKJ and GHIL.

To obtain the radii with which to strike the smaller curves in plan, place distances PF and PK on the lines RE and CJ in Fig. 35 as shown by RF and CK. Draw a line from F through K until it meets the line RO at P. Then PK and PF will be the radii with which to strike the pattern, for that part shown in plan in Fig. 34 by KFG L and HIEJ. Now divide the curve from G to H and H to E (Fig. 34) into a number of equal spaces. To describe the pattern draw any vertical line E'O' (Fig. 35) and with O' as center and radii equal to OJ and OE in the diagram Y, describe the arcs J'K' and E'F' as shown. On the arc E'F' lay off the stretch-

out of GH in plan in Fig. 34 as shown by similar figures in Fig. 35. From the point 6 on the arc E^1F^1 draw a line to O^1 intersecting the curve J^1K^1 . Now with P^1F^1 in diagram Y as radius and F^1 as a center describe an arc intersecting the line F^1O^1 at P^1 . Then using P^1 as a center and with radii equal to P^1K^1 and P^1F^1 describe the arcs K^1L^1 and F^1G^1 as shown. On the arc F^1G^1 starting from point 6 lay off the stretchout of HE.

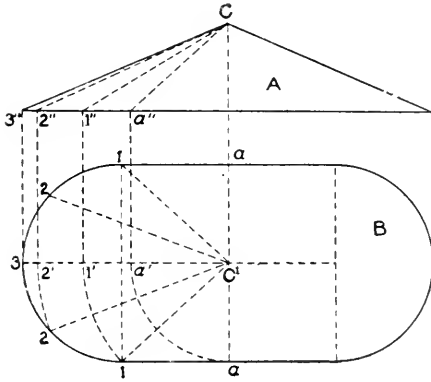

Fig. 34. From 11 draw a line to P^1 intersecting the arc K^1L^1 at L^1 . Then $E^1F^1G^1L^1K^1J^1$ will be the

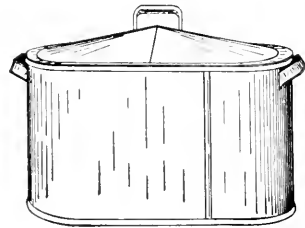

Fig. 36.

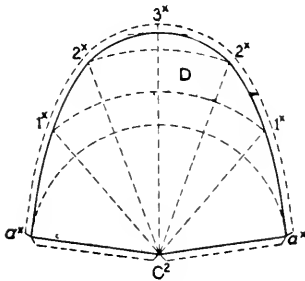

Fig. 37.

half pattern, the allowance for wiring and seaming being shown by the dotted lines.

Should the article be desired in four sections, two pieces of $F^1K^1L^1G^1$ would be required. The pattern for the bottom of

the pan is shown by the inner ellipse in Fig. 34 to which of course edges must be allowed for double seaming.

Wash Boiler. In Fig. 36 is shown a perspective view of a wash boiler to which little attention need be given, except to the raised cover. First draw the plan of the cover B, Fig. 37, which shows straight sides with semi-circular ends. In line with the plan draw the elevation A, giving the required rise as at C. Let C represent the apex in elevation, and C^1 the apex in plan. As both

halves of the cover are symmetrical, the pattern will be developed for one half only. Divide the semi-circle 1-3-1 into a number of equal spaces as shown by the small figures 1, 2, 3, 2 and 1. From these points draw radial lines to the apex C^1 , and through C^1 draw the perpendicular aa' . C^1B'' in elevation represents the true length of C^1B in plan, and to obtain the true length of C^12 , C^11 and C^1a , it will be necessary to construct a diagram of triangles as follows: With C^1 as center, and C^1a , C^11 and C^13 as radii, describe arcs intersecting the center line in plan at a' , $1'$ and $2'$. From these points at right angle to B^1C^1 erect lines intersecting the base line of the elevation at a'' , $1''$, $2''$



Fig. 38.

and $3''$, from which draw lines to the apex C^1 , as shown. Now, with radii equal to C^13'' , C^12'' , C^11'' and C^1a'' , and C^1 as center describe arcs 3^x , 2^x , 1^x and a^x . From C^2 erect the perpendicular intersecting the arc 3^x at 3^x . Now set the dividers equal to the spaces 3 to 2 to 1 to a in plan, and starting from 3^x step off to similar numbered arcs, thus obtaining the intersections $2^x1^xa^x$; from a^x draw lines to C^2 , and trace a line $a^x3^xa^x$ to get the half pattern for the cover. Allow edges for seaming.

The body of the boiler requires no pattern, as that is simply the required height, by the stretchout of the outline shown in plan. The handles shown on the body and cover in Fig. 36 are plain strips of metal to which wired or hem edges have been allowed.

Measure. Fig. 38 shows a flaring-lipped measure with handle attached. Care should be taken in laying out the patterns for these measures, that when the measure is made up it will hold a given quantity. While there are various proportions used in making up the size of the measure, the following table gives good proportions:

Quantity.	Bottom Diameter in inches.	Top Diameter in inches.	Height.
1 Gill.	2.06	1.37	3.10
$\frac{1}{3}$ Pint.	2.60	1.75	3.89
1 Pint.	3.27	2.18	4.90
1 Quart.	4.12	2.75	6.18
$\frac{1}{2}$ Gallon.	5.18	3.45	7.78
1 Gallon.	6.55	4.35	9.80

Fig. 39 shows the method of laying out the pattern for the measure and lip. First draw the elevation A to the desired size

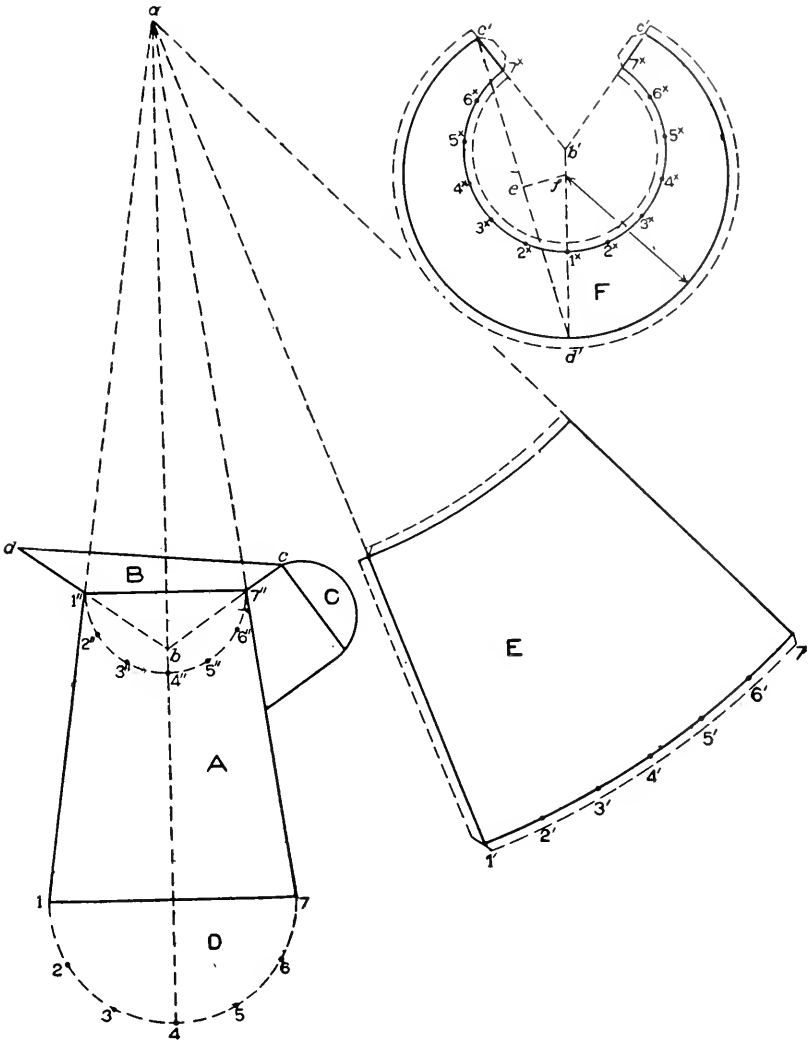

Fig. 39.

and assume the flare of the lip B, as shown by d' . From a draw a line through $7''$ to c which is a chosen point, and draw a line from c to d . Draw the handle C of the desired shape. Now extend contour lines of the measure until they intersect at a , and draw

the half section of the bottom of the measure as shown at D; divide this semi-circle into equal parts as shown. Now, with a as a center, and $a7$ and $a7''$ as radii, describe the arcs as shown. From any point (as $1'$) draw a radial line to a , and starting at $1'$ set off the number of spaces contained in the half section D, as shown by the small figures $1'$ to $7'$. From $7'$ draw a radial line to a . Allow edges for wiring and seaming. E represents the half pattern for the body of the measure. We find that lip B is simply an intersected frustum of a right cone, which can be developed as shown in the pattern for conical boss of Fig. 25.

There is, however, a shorter method which serves the purpose just as well; this is shown at F, Fig. 39. First draw the half section of the bottom of the lip, which will also be the half section of the top of the measure, as shown by the figures $1'$ to $7''$. Now, with radii equal to $b-1''$, or $b-7''$ and b' in F as center, describe the arc 7^x7^x . From b' drop a vertical line intersecting the arc at 1^x . Starting from the point 1^x , set off the spaces contained in the half section $1''-4''-7''$, as shown by the figures 1^x to 7^x . From b' draw lines through the intersections 7^x7^x , extending them as shown. Now take the distance from $1''$ to d of the front of the lip and place it as shown by $1^x d'$ in F. In similar manner take the distance from $7''$ to c of the back of the lip and place it as shown in F from 7^x to c' on both sides. Draw a line from c' to d' , and bisect it to obtain the center e . From e , at right angles to $c'd'$, draw a line intersecting the line $b'd'$ at f . Then using f as center, with radius equal to $f'd'$, draw the arc $c'd'e$, as shown. Adding laps for seaming and wiring will complete the pattern for the lips.

The pattern for the handle and grasp C is obtained as shown in Figs. 30 and 31.

Scale Scoop. Fig. 40 shows a scale scoop, wired along the top edges and soldered or seamed in the center. The pattern is made as shown in Fig. 41. First draw the elevation of the scoop as shown by ABCD. (In practice the half elevation, BDC, is all that is necessary.) At right angles to BD and from the point C, draw the indefinite straight line CE, on which a true section is to be drawn. Therefore, at right angles to CE, from points C and E, draw the lines CC and EE'. From E' erect a perpendicular as E'C, on which at a convenient point locate the center F; with

FE' as radius, describe the arc HE'F. Then HE'F will be the true section on CE in elevation. Divide the section into a number of equal parts as shown by the figures 1 to 7; through these points, parallel to the line of the scale BD, draw lines intersecting BC and CD as shown. At right angles to BD draw the stretchout line 1-7 and place upon it the stretchout of the section as shown by similar figures. At right angles to 1-7 draw lines which intersect

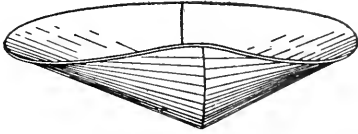

Fig. 40.

lines drawn at right angles to BD, from intersections on BC and DC having similar numbers. Trace a line through these

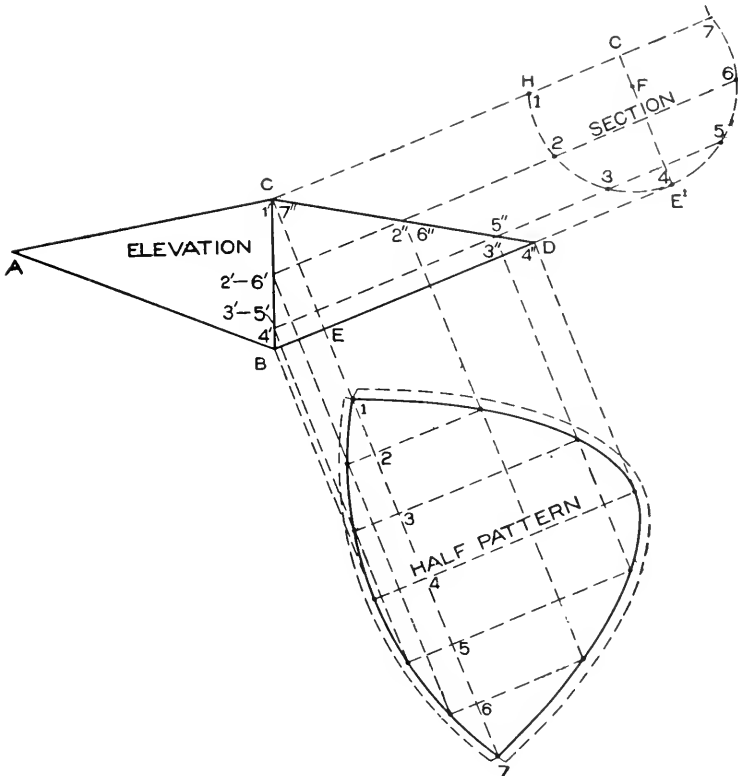

Fig. 41.

points and thus obtain the desired pattern. The dotted outline shows the lap and wire allowance.

In Fig. 42 is shown a perspective view of a **dust pan** with a tapering handle passing through the back of the pan and soldered to the bottom. The first step is to draw the plan and elevation which is shown in Fig. 43. Let ABC be the side view of the pan. Directly below it, in its proper position, draw the bottom DEFG. From the point C in elevation draw a line $d'd'$ indefinitely. Now bisect the angle EFG. Through e and F draw the line el , intersecting the line $d'd'$ at d . From d draw a line to G.

In the same manner obtain $E'd'D$ on the opposite side, which

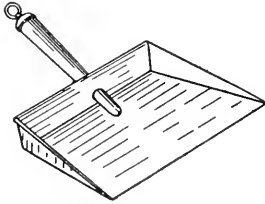

Fig. 42.

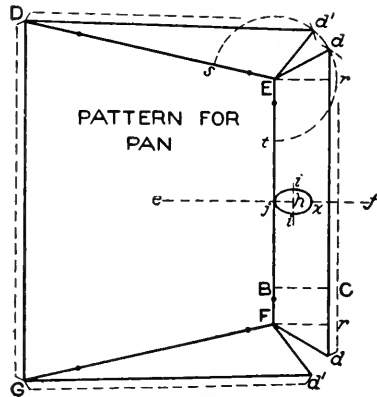

Fig. 44.

will complete the plan view of the pan. Now locate the point h in side view, through which the center line of the handle shall pass, and draw the line m . Through m , the end of the handle, draw the line no at right angles to lm , and assume o the half width at the top and j the point where the contour line of the handle shall meet the back of the pan, and draw a line from o through j , intersecting the center line lm at l . Make mn equal to mo and draw a line from n to l , intersecting the back of the pan at x . Through h at right angles to the center line draw ij' , giving the diameter of the handle at that point to be used later. This completes the elevation of the handle; the plan view is shown by dotted lines and similar letters, but is not required in developing the pattern.

For the pattern of the pan proceed as is shown in Fig. 44, in which DEFG is a reproduction of similar letters of Fig. 43. Take the distance of BC in side view, Fig. 43, and place it as shown by

BC' in Fig. 44 and through C' draw a line parallel to EF as shown. At right angles to and from EF draw Ee' and Ff' , then take the distance from r to l in plan in Fig. 43 and place it as shown from r' to l' on both sides in Fig. 44. Draw the lines $d'F$ and $d'E$. Now using E as center, and radius equal to Ee' describe the arc st . Then with tl as radius and s as center, intersect the arc st at d' . Draw a line from d' to D. In similar manner obtain $d'G$ on the opposite side, which will complete the pattern for the pan. Allow laps for wiring and edging.

The opening in the back of the pan to allow the handle to pass through is obtained by first drawing a center line ef , then take the distances from j to h and h to x in Fig 43, noting that j comes directly on the bend B, and place it in Fig. 44 on the line ef

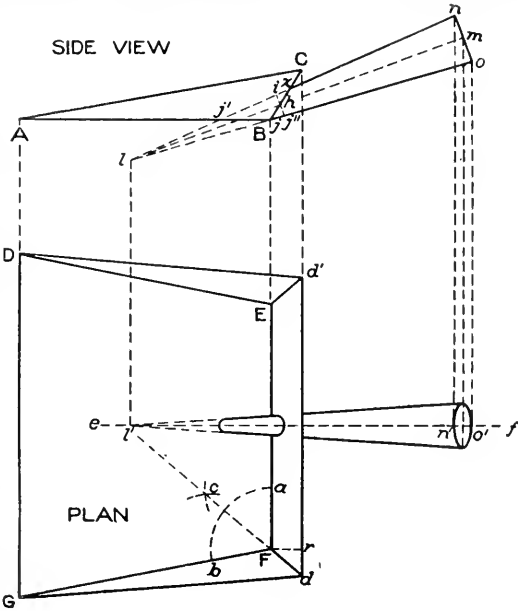

Fig. 43.

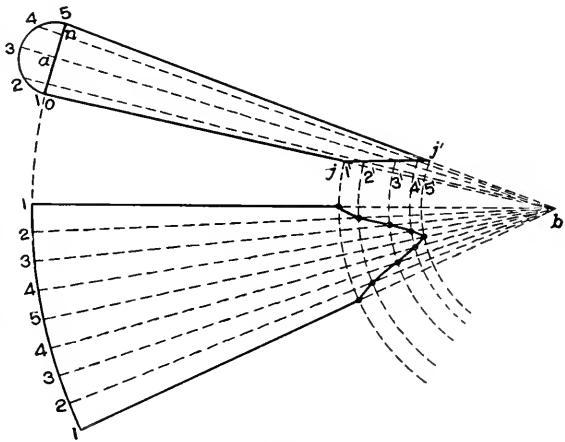

Fig. 45.

from j to h to x , placing j on the bend as shown. Now take the distance from h to i or h to j'' in side view in Fig. 43 and place it in Fig. 44 from h to i on either side; on a line drawn through the points $j'i'i$ draw an ellipse shown. Fig. 45 shows the method of drawing the pattern for the tapering handle. From the figure we find that we have a frustum of a right cone. To illustrate each step the handle has been slightly enlarged. u, o, j, j'' represents u, o, j, j'' in Fig. 43. Draw the half section in Fig. 45 as shown, and divide it into equal parts;

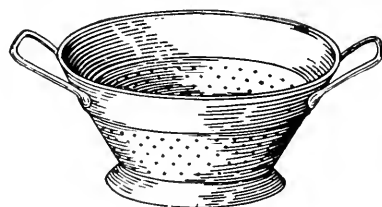

Fig. 46.

meet at b . Where the radial lines intersect the line $j'j''$ draw lines at right angles to the center line $3b$, intersecting the side of the handle ob at $1', 2', 3', 4'$ and $5'$.

Now with b as a center and bo as a radius, describe the arc 1-1, upon which place twice the number of spaces contained in the half section o . From these points on 1-1 draw radial lines to b and cut them with arcs struck from b as center and radii equal to $b1', b2', b3', b4'$ and $b5'$. Trace a line through points thus obtained to complete the pattern.

Colander. Fig. 46 shows another well-known form of tin ware, known as a colander. The top and bottom are wired and the foot and body seamed together, the handles of tinned malleable iron being riveted to the body. In Fig. 47 is shown how to lay out the patterns. Draw the elevation of the body A and foot B and extend the sides of the body and foot until they meet respec-

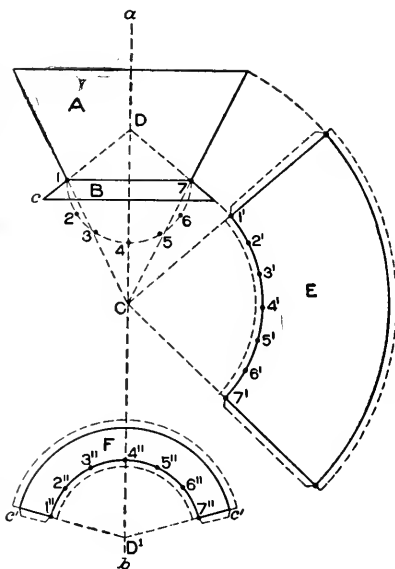

Fig. 47.

tively at C and D on the center line ab . Draw the half section on the line 1-7 and divide it into equal parts as shown. For the body, use C as a center and describe the arcs shown, laying off the stretchout on the lower arc, allowing edges in the usual manner. Then E will be the half pattern for the body. In the usual manner obtain the pattern for the foot shown at F, the pattern being struck from D' as center, with radii obtained from the elevation D1 and Dc.

PLATES.

In preparing the plates, the student should practice on other paper, and then send finished drawings for examination. The plates of this instruction paper should be laid out in the same manner and of the same size as the plates in Mechanical Drawing Parts I, II and III.

PLATE I.

On this plate, the intersection between two right cones is shown. This problem arises in the manufacture of tinware in such instances as the intersections between the spout and body as in a teapot, watering pot, kerosene-oil can, dipper handle and body, and other articles. It is one of the most complicated problems arising in tinsmith work. The problem should be drawn in the center of the sheet making the diameter of the base A 4 inches and the height of the cone B $4\frac{1}{2}$ inches. The distance from X to Y should be 1 inch. From the point F measure down on the side of the cone a distance of $3\frac{1}{8}$ inches and locate the point C, from which draw the axis of the smaller cone at an angle of 45° to the axis of the larger cone. From C measure on CL $1\frac{5}{8}$ inches locating the point G'; through this point, at right angles to the axis, draw ED equal to $1\frac{1}{2}$ inches. From the point F' on the base of the cone, measure up on the side of the cone a distance of $\frac{1}{2}$ inch as indicated by o , and draw a line from o to E, extending it, until it intersects the axis LC at L. From L draw a line through D extending it until it intersects the larger cone at o . Then D o o E will represent the outline of the frustum of the smaller cone in elevation.

The next step is to obtain the line of intersection between the two cones, but before this can be accomplished, horizontal

sections must be made through various planes of the smaller cone cutting into the larger. As the intersection of each half of the smaller cone with the larger one is symmetrical, and as the small cone will not intersect the larger one to a depth greater than the point 1 in plan, divide only one-quarter of the plan into a number of equal spaces as shown by figures 1 to 4; from these points draw radial lines to the center F^1 as shown. Also from points 1, 2, 3 and 4 erect vertical lines intersecting the base of the cone at 1', 2', 3' and 4' respectively, from which points draw radial lines to the apex F.

Now with G' on the line ED as a center describe the circle shown, which represents the true section on ED. Divide each semi-circle into the same number of divisions as shown by the small figures D, 5, 6, 7, and E on either side. From these points at right angles to ED draw lines intersecting the center line ED at 5, 6' and 7'. From the apex L draw lines through the intersection 5', 6 and 7', and extend them until they intersect the axis of the large cone at e and the base line at k and n . The student may naturally ask why the radial lines in the small cone are drawn to these points. As it is not known how far the smaller cone will intersect the larger one, we obtain such sections on the planes just drawn, as we think will be required to determine the depth of the intersection. Thus the radial line drawn through 5' intersects the radial lines through 4', 3', 2' and 1' in the larger cone, at b , c , d and e respectively. The radial line through 6' intersects radial lines in the larger cone at f , h , i , j and the base line at k , while the radial line drawn through the point 7', intersects the radial lines of the larger cone at l and m and the base at n . We know that the line Dd and Ee of the smaller cone intersect the larger cone at points a and o respectively, and determine the true points of intersection; these are shown in plan by a' and o' , and therefore no horizontal sections are required on these two planes. For the horizontal section on the plane $b c$, drop vertical lines from the intersections b , c and d on the radial lines, intersecting radial lines having similar numbers in plan as shown by b' , c' and d' . To obtain the point of intersection in plan of e in elevation, draw from the point e a horizontal line intersecting the side of the cone at e^x , from which point drop a perpendicular line intersecting the center line in plan at e^y .

Then using F^1, v as radius, describe an arc intersecting the radial line 1 at c' . Through the points c', d', e' and b' draw a curved line, which is the half horizontal section of $b'c'$ in elevation. In the same manner obtain the sections shown in plan by j', k', i', j' and k' ; and l', m' and n' , which have similar letters and figures in both plan and elevation. The next step is to obtain the intersections where the radial lines of the smaller cone will intersect these sections in plan just obtained. To avoid a confusion of lines which would otherwise occur, a reproduction of the plan and elevation has been transferred to Plate II.

PLATE II.

The figures on this plate are similar to those on Plate I and have similar letters and figures; those letters and figures being omitted which are not necessary. This plate should be studied carefully before proceeding. The reproducing from Plate I can be best done by using a needle point or the small needle which is usually found in the handle of the drawing pen, when unscrewing the pen from the handle, and pricking through Plate I, very small indistinct prick marks. Omit all that is omitted in Plate II, where it will be noticed that the radial line in elevation, of the larger cone, and some of the various small letters in plan are not represented.

To obtain the plan view of the smaller cone, proceed as follows: Extend the line $F^1 4$ in plan as shown by $F^1 E^1$. From the apex L of the smaller cone drop a vertical line intersecting $F^1 E^1$ at L^1 , which represents the apex of the smaller cone in plan. With L^1 as center and radius equal to the radius $G' D$ describe the circle $E^1 D^1$ and divide the circumference into the same number of spaces as ED , being careful to number the spaces as is there shown. The reason for doing this may be better understood from what follows: Assume that ED is a pivot on which the circle turns, so that it lies on a plane ED , then by looking down from the top, the points 6 and $6'$ appear as shown by $6'$ and $6'$ in plan.

A better illustration is obtained by cutting a card-board disc and after spacing it and numbering the points hold it in various positions until all the points become clear. Now from the intersections on ED in elevation, drop lines, intersecting horizontal lines drawn from similar numbered points in the profile $E^1 D^1$,

thus obtaining the points of intersection D^v , 5^v , 6^v , 7^v and E^v . Trace a curved line through these points, which will give the top view of ED. As the radial lines drawn through the points $5'$, $6'$ and $7'$ on the line ED of the smaller cone in elevation intersect the section lines $b'e$, $f'k$ and $l'n$ respectively, the radial lines in plan drawn through the apex L^1 and points 5^v , 6^v , and 7^v must intersect similar section lines in plan $b'e'$, $f'k'$ and $l'n'$ respectively, as shown by points 5^x , 6^x and 7^x . The points a' and o' are obtained by dropping perpendiculars from the points a and o in elevation onto the line $E^1 F^1$ in plan. Through the points thus obtained, draw the curved line a' , 5^x , 6^x , 7^x , o' which will represent the plan view of one-half of the intersection between the two cones, the other half being similar.

Now from the intersections 5^x , 6^x and 7^x on the section lines $b'e'$, $f'k'$ and $l'n'$ respectively, erect perpendicular lines intersecting similar section lines in elevation $b'e$, $f'k$ and $l'n$ as shown respectively by points 5° , 6° and 7° .

A curved line traced through a , 5° , 6° , 7° and o will represent the line of intersection between the two cones in elevation. At right angles to the axis of the smaller cone and from the intersections a , 5° , 6° and 7° draw lines intersecting the side of the cone Eo at D^A , 5^A , 6^A and 7^A . For the pattern of the smaller cone proceed as is shown in the following plate:

PLATE III.

On this plate the two patterns should be placed in the center of the sheet. Take the radius of LD in Plate II and with L in Fig. 1 of Plate III as center describe the arc DD. From L drop a vertical line as shown by $L E^A$. Upon the arc DD measuring from either side of the point E, lay off the stretchout of the semi-circle E, 7, 6, 5, D in Plate II as shown by similar letters and figures on DD in Fig. 1 Plate III. From the apex L and through these points draw radial lines as shown and intersect them by arcs whose radii are equal to $L D^A$, $L 5^A$, $L 6^A$, $L 7^A$ and $L E^A$ in Plate II, as shown by similar letters and figures in Plate III. Trace a line through points thus obtained, and D, E, D, D^A , E^A , D^A , D will be the pattern for the small cone. As the pattern for the larger cone is obtained in the usual manner, we will only show how to obtain the opening to be cut into one side of the larger

cone to admit the intersection of the smaller. We must now again refer to Plate II. From the intersections a , 5, 6, 7, and o in elevation draw lines at right angles to the line of the axis, intersecting the side of the cone at 4^B , 5^B , 6^B , 7^B and 4^B .

Also in addition to the spaces 1, 2, 3 and 4 in the plan view, it will be necessary to obtain the points of intersection on the base line in plan, where the radial lines would intersect drawn from the apex F^1 through the points of intersections between the two cones. This is accomplished by drawing lines from F^1 through 5^x , 6^x and 7^x until they intersect the base line in plan at 5, 6 and 7. All these points form the basis with which to develop the pattern shown in Fig. 2 of Plate III, in which draw the vertical line $F 4$, and with F as a center and radii equal to $F Y$, and $F P$ in Plate II draw the arcs $Y Y$ and $P P$ in Fig. 2 of Plate III as shown. Now starting from the point 4 on the arc $P P$ on either side, lay off the stretchout of 1, 6, 5, 7 and 4 in plan in Plate II as shown by similar numbers in Fig. 2 of Plate III. From the points 6, 5, 7 and 4 on either side draw radial lines to the apex F , which will be used to obtain the pattern for the opening. Now with F as center and radii equal to $F 4^B$, $F 5^B$, $F 6^B$, $F 7^B$ and $F 4^B$ in Plate II, describe arcs intersecting radial lines having similar numbers in Fig. 2 of Plate III as shown by intersections having similar numbers. A line traced through these points will be the required opening to be cut out of the pattern of the larger cone, one-half of which is shown by drawing radial lines from the points 1 and 1 to the apex F .

PLATE IV.

In drawing this plate, the same size paper and border lines should be used as for the preceding plates. The subject for this plate is an oil tank resting on inclined wooden racks. The problem involves patterns in parallel and radial-line developments. The drawing can be made to any convenient scale until the problems are understood and should be proven by paste-board models. It should be drawn to a convenient scale, placing the pattern to fill the sheet and make a neat appearance. The section, stretch-out lines, construction lines, and developments should be numbered or lettered, so as to prove the thorough understanding of the problem, and then sent to the School for correction. The var-

ious parts in the elevation and patterns have similar letters. A represents the tank body, the pattern being shown by A¹. B shows the bottom, the pattern being shown by B¹. The cone top C and inlet D are shown developed by C¹ and D¹ respectively, while the outlet E and opening F in elevation are shown developed by E¹ and F¹ in the bottom B¹.

EXAMINATION PLATES.

Drawing Plates I to IV inclusive constitute the examination for this Instruction Paper. The student should draw these plates in ink and send them to the School for correction and criticism. The construction lines and points should be clearly shown. The date, student's name and address, and plate number should be lettered on each plate in Gothic capitals.

TABLE OF STANDARD OR REGULAR TIN PLATES.

Size and Kind of Plates, Number and Weight of Sheets in a Box, and Wire Gauge Thickness, of Every Kind and Size.

Size.	Grade.	Sheets in Box.	Pounds in Box.	Wire Gauge.
10 x 10	IC	225	80	29
"	IX	225	100	27
"	IXX	225	115	26
"	IXXX	225	130	25
"	IXXXX	225	145	24 1-2
10 x 14	IC	225	112	29
"	IX	225	140	27
"	IXX	225	161	26
"	IXXX	225	182	25
"	IXXXX	225	203	24 1-2
"	IXXXXX	225	224	24
"	IXXXXXX	225	245	23 1-2
10 x 20	IC	225	160	29
"	IX	225	200	27
11 x 11	IC	225	95	29
"	IX	225	121	27
"	IXX	225	139	26
"	IXXX	225	157	25
"	IXXXX	225	175	24 1-2
11 x 15	SDC	200	168	26
"	SDX	200	189	25
"	SDXX	200	210	24 1-2
11 x 15	SDXXX	200	230	24
12 x 12	IC	225	112	29
"	IX	225	140	27
"	IXX	225	161	26
"	IXXX	225	182	25
"	IXXXX	225	203	24 1-2
"	IXXXXX	225	224	24
"	IXXXXXX	225	245	23 1-2
12 1-2 x 17	DC	100	98	28
"	DX	100	126	26
"	DXX	100	147	24
"	DXXX	100	168	23
"	DXXXX	100	189	22
"	DXXXXX	100	210	21
13 x 13	IC	225	135	29
"	IX	225	169	27
"	IXX	225	194	26
"	IXXX	225	220	25
"	IXXXX	225	245	24 1-2
13 x 17	IXX	225	254	26
13 x 18	IX	225	234	27
"	IXX	225	269	26
14 x 14	IC	225	157	29
"	IX	225	196	27
"	IXX	225	225	26
"	IXXX	225	255	25

TABLE OF STANDARD OR REGULAR TIN PLATES.---Con.

Size.	Grade.	Sheets in Box.	Pounds in Box.	Wire Gauge.
14 x 14	IXXXX	255	284	24 1-2
14 x 17	IX	225	238	27
14 x 20	IC	112	113	29
"	IX	112	143	27
"	IXX	112	162	26
"	IXXX	112	183	25
"	IXXXX	112	202	24 1-2
15 x 15	IX	225	225	27
"	IXX	225	259	26
"	IXXX	225	293	25
"	IXXXX	225	326	24 1-2
15 x 21	IX	112	158	27
"	DXX	100	218	24
"	DXXX	100	249	23
"	DXXXX	100	280	22
15 x 22	IXX	112	190	26
"	SDXX	100	210	24 1-2
"	SDXXX	100	230	24
16 x 16	IC	225	205	29
"	IX	225	256	27
"	IXX	225	294	26
"	IXXX	225	333	25
"	IXXXX	225	371	24 1-2
17 x 17	IC	225	231	29
17 x 17	IX	225	289	27
"	IXX	112	166	26
"	IXXX	112	188	25
"	IXXXX	112	210	24 1-2
17 x 25	DC	100	196	28
"	DX	100	252	26
"	DXX	50	146	24
"	DXXX	50	168	23
"	DXXXX	50	189	22
"	IX	112	213	27
"	IXX	112	244	26
18 x 18	IX	112	162	27
"	IXX	112	186	26
"	IXXX	112	211	25
"	IXXXX	112	235	24 1-2
19 x 19	IC	112	144	29
"	IX	112	180	27
"	IXX	112	207	26
"	IXXX	112	234	25
"	IXXXX	112	262	24 1-2
20 x 20	IC	112	160	29
"	IX	112	200	27
"	IXX	112	230	26
"	IXXX	112	260	25
"	IXXXX	112	290	24 1-2
20 x 28	IC	112	224	29
"	IX	112	280	27
"	IXX	112	322	26

TERNE PLATES.

Size.	Grade.	Sheets in Box.	Pounds in Box.	Wire Gauge.
14 x 20	IC	112	112	29
"	IX	112	140	27
20 x 28	IC	112	224	29
"	IX	112	280	27
20 x 200	IC	Roll	176	29
"	IX	"	220	27

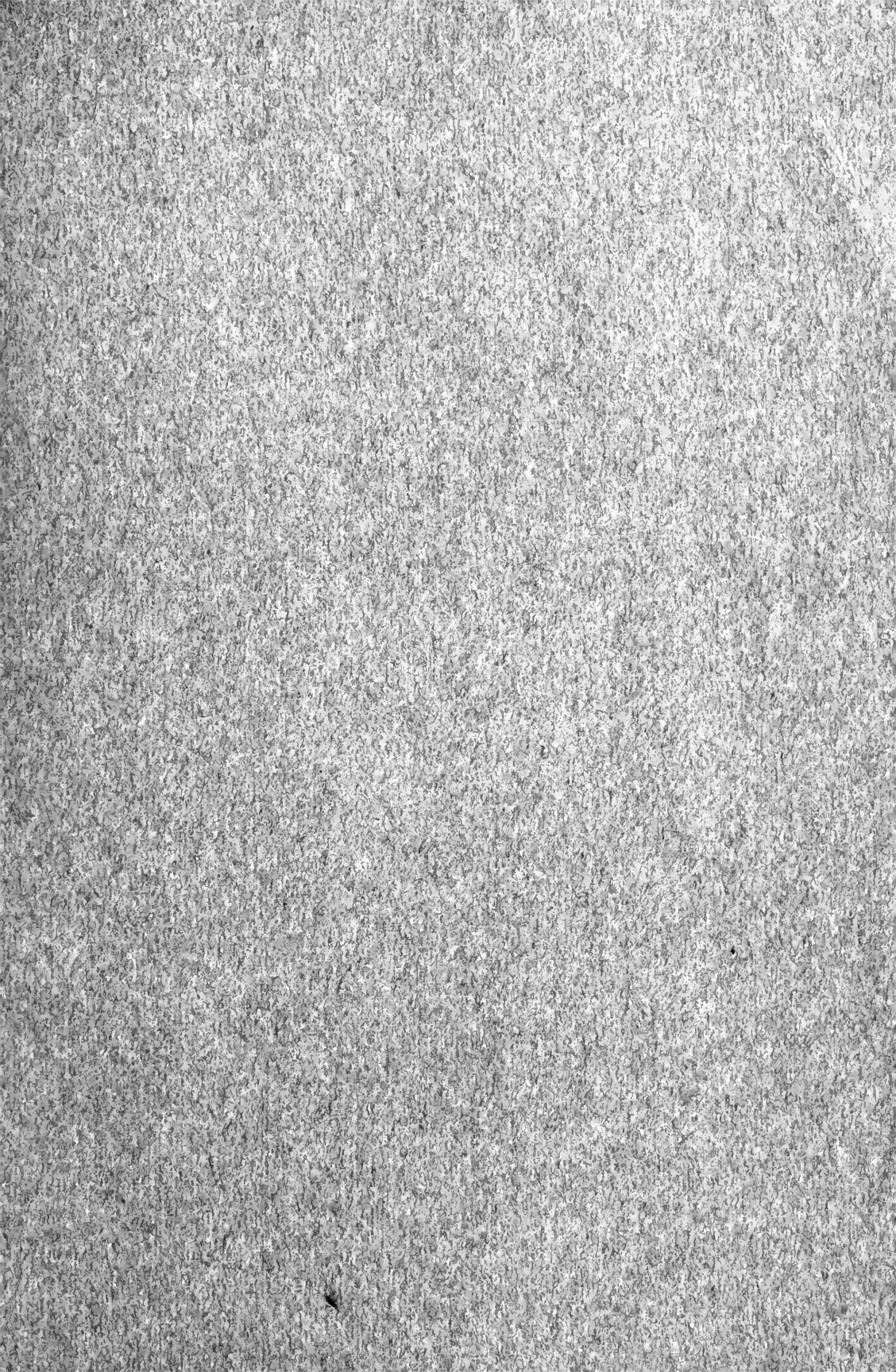

LIBRARY OF CONGRESS



0 014 757 464 2

